

Martin Krus, Klaus Sedlbauer, Herbert Sinnesbichler

Artificial thermal bridge with a dew point switch to accomplish an appropriate control of the ventilation for the prevention of mould growth in buildings

Fraunhofer-Institute of Building Physics,
Valley/Oberlindern, Germany

Abstract

The well known problem of global warming due to the green house effect has provoked the Kyoto Protocol, which first of all means energy saving. In colder regions the highest amount of energy is consumed by the heating of buildings. Beside a better insulation the diminishment of ventilation losses is a common way for saving energy. Unfortunately this increases the risk of mould growth, which is determined by the temperature and relative humidity of the inner wall surface. An appropriate ventilation system has to prevent surface conditions suited for mould. For energy saving purposes permanent ventilation is no solution. Instead the ventilation has to take place subjected to unsteady humidification processes like cooking or bathing. The measurement of surface temperature and humidity to control the ventilation is too expensive and needs continuous maintenance. Instead the proposed innovative control system uses a thermal bridge, designed in such a way, that there dew water occurs just at the same time, when in problematic areas like corners conditions for mould are reached. The thermal bridge is equipped with a dew sensor switching the ventilator. Just when condensation has stopped and the surface of this sensor has dried the ventilator will be deactivated. This ensures that the ventilation occurs only when required. Additional advantages are the simplicity and cheapness of this system combined with the lack of necessary service.

Keywords: Prevention of mould, ventilation control, dew point switch

1 Introduction

The growth of mould is frequently observed after carrying out energy-saving renovation measures in existing buildings (i.e. installation of air-tight windows) due to traditional but now insufficient way of airing the rooms (see figure 1). Mould growth on the interior surfaces of external component parts may be a risk to the health of the occupants.

It is possible to avoid fungal decay in rooms for a certain period of time by using biocides or similar agents, yet health risks caused by these products cannot be excluded. Temperature and humidity are the decisive factors to allow the growth of mould. Figure 2 shows the life cycle of mould fungi. However, indoor air temperature and humidity are not decisive for the risk of mould growth, but the hygrothermal boundary conditions on the internal wall surface. It is important to know that mould growth doesn't need condensed water.

Depending on the temperature mould growth may start already at surface moistures of approximately 75 % relative humidity.



Figure 1 Here an adequate ventilation is only possible by drafty windows or by means of additional ventilation equipment

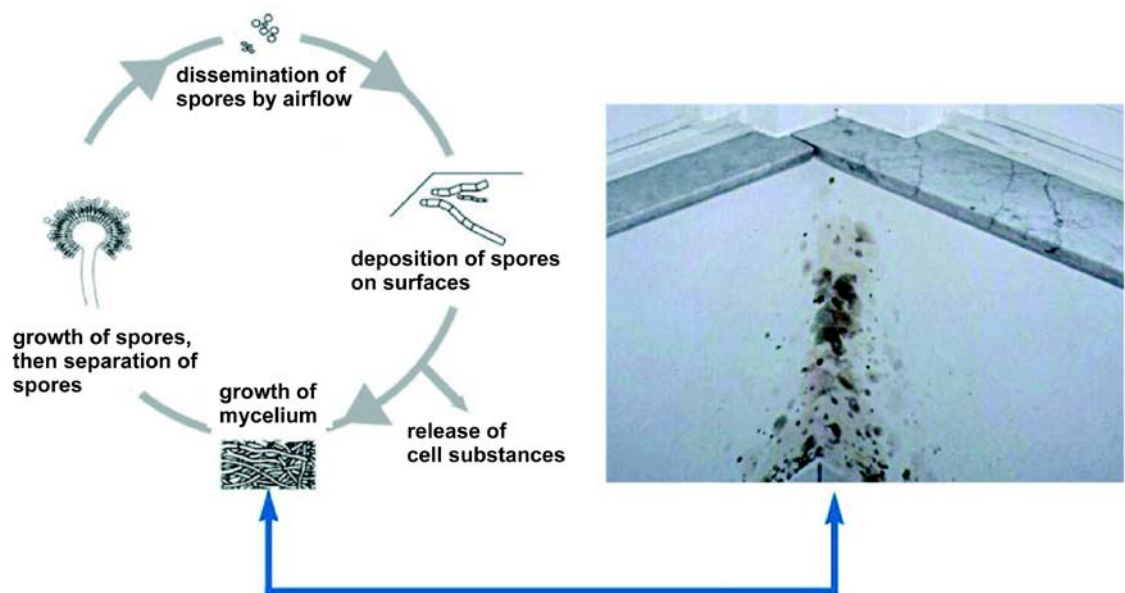

Figure 2 Life cycle of mould fungus

Consequently, an adequate ventilation system which is to prevent the growth of mould, must ensure that these boundary conditions on surfaces do not occur, at least not for longer periods. An enforced permanent ventilation is not

acceptable from the energetic point of view. Ventilation must occur depending on the boundary conditions on the surfaces caused primarily by transient moisturising processes (cooking, showering etc.). But permanently measuring the surface moisture and surface temperature is hardly justifiable the complexity and costs. Therefore, in most cases, ventilation systems are controlled only by air quality (CO₂ concentration) at present, whereas moisture load and the risk of mould growth remain unconsidered.

2 Development concept

The novel concept described here is to install an artificial thermal bridge at selected positions of an external wall. By means of innovative modelling programmes (WUFI ([1], [2])), Hygrothermal Room Model [3], Biohygrothermal Method for Assessing the Risk of Mould Growth [4], [5], which were developed at the Institute of Building Physics (IBP), this "thermal bridge" can be thermally designed in a way that condensed water is formed there as soon as the surface moisture on the interior surface of an external wall in problematic areas (i.e. corners) has just reached a value to allow mould growth. Figure 3 shows a draft of the simple design of such an artificial "thermal bridge".

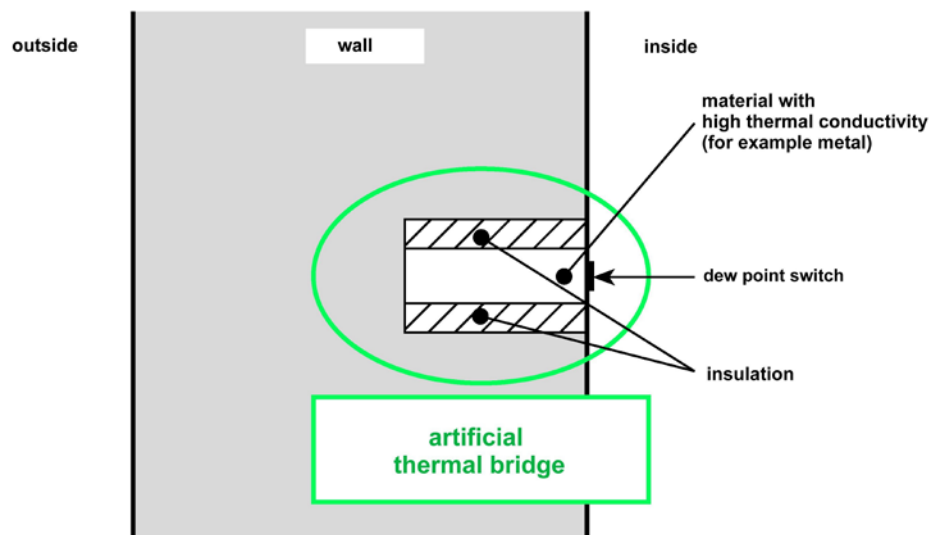

Figure 3 Schematic design of an artificial "thermal bridge" with dew point switch

If simple switching dew point switches are installed on the internal surface of this artificial "thermal bridge" (design for example as shown in figure 4, but also simple resistive sensors or similar equipment), ventilation systems can be activated this way as long as dewing conditions exist. As soon as dewing conditions cease, the ventilation system will be switched off automatically, since it is no longer needed.

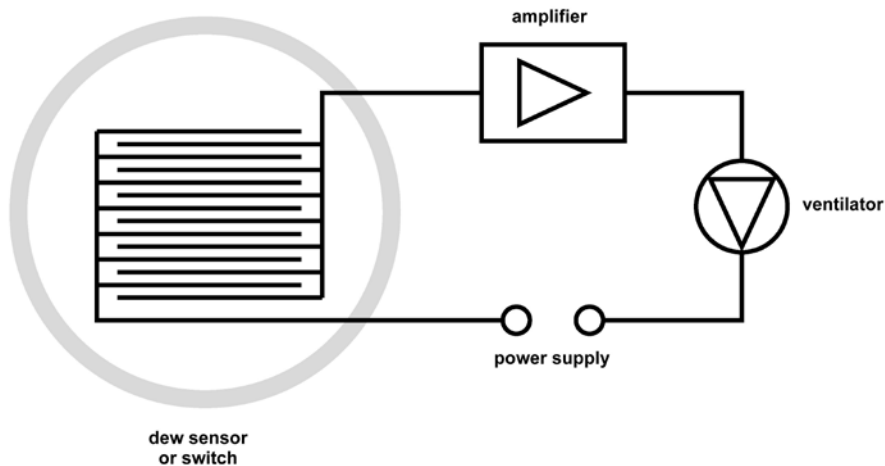

Figure 4 Schematic design of a dew point switch to control ventilation

The advantage of using a dew point switch is that the ventilation will be switched on only if the external air temperature is below the internal air temperature, conforming with the principles of building physics. The ventilation system is running only when the indoor humidity is high and the temperature of the interior wall is so much lower than the indoor air temperature that the moisture on the interior surfaces will be too high. Thus, unnecessary or even harmful ventilation is almost impossible. The significant advantage of applying this kind of dew point switch is that it works without any additional measurement equipment. It is cheap and virtually maintenance-free, and regular calibration measures are unnecessary.

3 Prospects

The patent for the described development concept has already been granted [6]. In the near future it is intended to design a model, consisting of a dew point switch and a suitable ventilation system to test practical feasibility. It is planned to use standard equipment to the greatest possible extent. The model will be tested in the laboratory in a climate chamber under different boundary conditions at first. Then the results will be used to optimise the design.

Later, outdoor testing will be carried out at test houses. The outdoor testing site of the IBP has two buildings, identical in construction ("twin houses"), where the operability of the newly developed system can be tested under realistic conditions as well as its advantages in comparison to conventional solutions. These tests should be carried out during at least one heating period. For this reason, it would be desirable to start the examinations in late autumn to be able to test the most interesting period, namely the cold winter months, from the very beginning.

4 References

- [1] Künzel H.M. 1995. Simultaneous Heat and Moisture Transport in Building Components. - One- and two-dimensional calculation using simple parameters. IRB Verlag Stuttgart (1995), pp 1-154, ISBN 3-8167-4103-7.
- [2] Krus, M.: Moisture Transport and Storage Coefficients of Porous Mineral Building Materials. Theoretical Principles and New Test Methods. IRB-Verlag Stuttgart (1996),pp 1-172, ISBN 3-8167-4535-0.
- [3] Holm, A.; Sedlbauer, K.; Künzel, H.M.; Radon, J.: Berechnung des hygrothermischen Verhaltens von Räumen – Einfluss des Lüftungsverhaltens auf die Raumluftfeuchte (Calculation of the hygrothermal behaviour of rooms – Influence of the ways of airing on the relative humidity of the room). Tagungsbeitrag für das 11. Bauklimatische Symposium der TU Dresden. 26. – 30. Sep. 2002, Dresden, pp 562 – 575.
- [4] Sedlbauer, K.: Beurteilung von Schimmelpilzbildung auf und in Bauteilen (Assessment of mould growth on and in building components). Thesis University of Stuttgart (2001).
- [5] Sedlbauer, K; Krus, M; Zillig, W.: Vorhersagemodell zur Schimmelpilzbildung bei Wechselklima – Praktische Beispiele. Tagungsbeitrag zum Architekten- und Ingenieurtag zum Thema Bauphysik im Holzbau (A new model for mould prediction for transient ambient conditions - Practical Examples). 27. Apr. 2002, Nürnberg, pp 43 - 55.
- [6] Sedlbauer, K; Krus, M; Sinnesbichler, H.: Verfahren und Vorrichtung zur Vermeidung von Schimmelpilzbefall (Method and device for the prevention of mould growth) . Patent Nr. DE10321253, 7. Mai 2003.